

STEAM SYSTEMS

Steam systems are practical for any size or type of building. Steam is comparatively easy to move through piping and radiation of large buildings and has the big advantage of providing a rapid response to the demand for heat.

The modern systems operate with varying steam temperatures and supply heat at various rates as the weather requires.

ONE-PIPE GRAVITY SYSTEM

The first steam heating system developed was the one-pipe system. It can be used in buildings of moderate size where radiation can be installed at least 24" above the boiler water line.

Advantages are: (1) **Simplicity of operation.** (2) **Low initial cost for small jobs.**

Disadvantages are: (1) **Piping and radiator valves must necessarily be large,** since steam and water must flow in opposite directions through the same pipe. (2) **Water hammer** (which results from the contact of steam with cold water) causes disturbing noise. (3) **Air valves must be used;** (except where of a type adapted to use with air return pipe) they are apt to spurt water, or fail to open dependably, and the result is a slow "heat-up" and therefore excessive fuel consumption. (4) **Difficulty of maintaining comfortable room temperatures** except by opening or closing radiator valves. If flow of steam from the boiler is automatically controlled, only "on" or "off" control is possible and fluctuating room temperatures result.

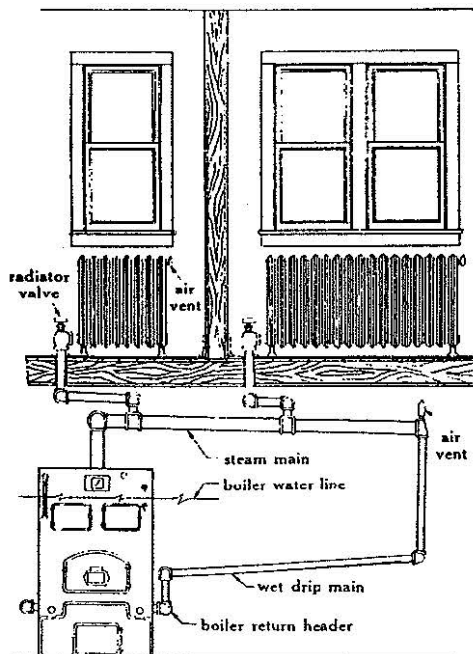

One-pipe steam system piping connections. One pipe carries steam to the radiators and drains water of condensation back to the boiler. Air is vented through an air valve at each radiator and at the end of the main.

TWO-PIPE GRAVITY SYSTEM

In an effort to overcome the difficulty of steam and water flowing against one another in the same pipe, the two-pipe system was developed. This system can be used in buildings of moderate size where radiation can be installed at least 24" above the boiler water line.

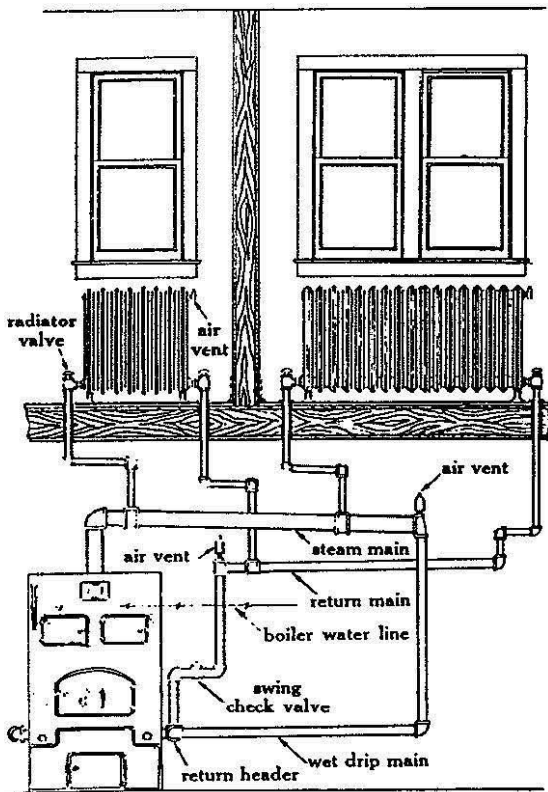

Two-pipe, two-valve gravity steam system piping connections. Steam flows through the supply main to radiators and returns to the boiler through a separate return main.

Except for eliminating the counterflow of steam and water in the supply piping, disadvantages of the one-pipe system are all present. Other disadvantages include: (1) A valve must be installed at each end of a radiator in order to shut off the steam; otherwise steam may be present in both supply and return piping. (2) The return from each radiator must be connected separately into a wet return or otherwise water sealed (which is costly and often impractical). (3) The mid-portion of the radiator is apt to become air bound (if the radiator return is not water sealed). This occurs particularly during the "heat-up" period, when steam fills the radiators nearest the boiler and flows through them into the return piping and then into the outlet connection of more distant radiators.

VAPOR SYSTEM

This is one of the early steam systems where thermostatic traps were used at each radiator and at the ends of steam mains. Radiator inlet valves were of the graduated or orifice type. Operation was at very low pressures, ounces were used instead of pounds per sq. inch. This system can be used in buildings where 24" or more can be provided between the boiler water line and the end of the return main.

Advantages are: (1) Even, quiet circulation of steam without objectionable water hammer or air binding. (2) Ability to continue supplying heat after the fire under the boiler has declined. The system is closed and since air cannot enter, a moderate vacuum is created by the condensing of the steam. When this moderate vacuum exists, steam is generated at lower temperatures. (3) Room temperatures can be controlled automatically by a thermostatic control of the fire or burner. (4) Air valves are not necessary. (5) Orifices can be used to balance distribution.

Disadvantages are: (1) Only low steam pressures are possible. (2) Operating steam pressure is limited by the headroom in the basement. (3) Condensate must return to the boiler by gravity. (4) Relatively large pipe sizes are necessary.

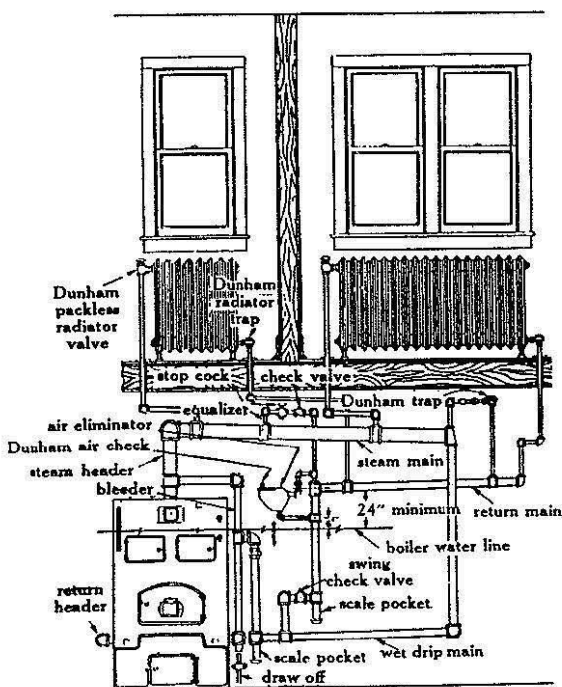

Vapor system piping connections. Thermostatic traps permit passage of water and air into the return piping but prevent the passage of steam. The return pipe carries water and air only, and the air is expelled through an air eliminator, the water returns to the boiler by gravity.

NOTE: Since water must return to the boiler by its own weight, it will tend to back up in the vertical return pipe when there is excess steam pressure in the boiler. Therefore, the air eliminator must be installed well above the boiler water line, yet low enough for it to close before the water is at a sufficiently high level to enter the return main. The system requires a close control of boiler pressure.

Pipe sizes are listed on page 66.

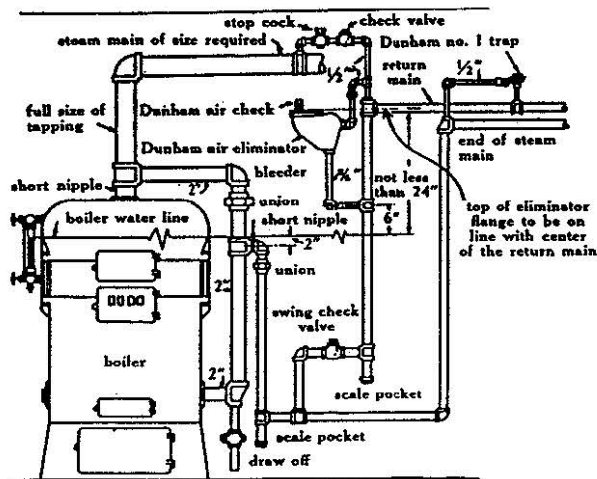

Vapor system piping to a boiler with one supply tapping.

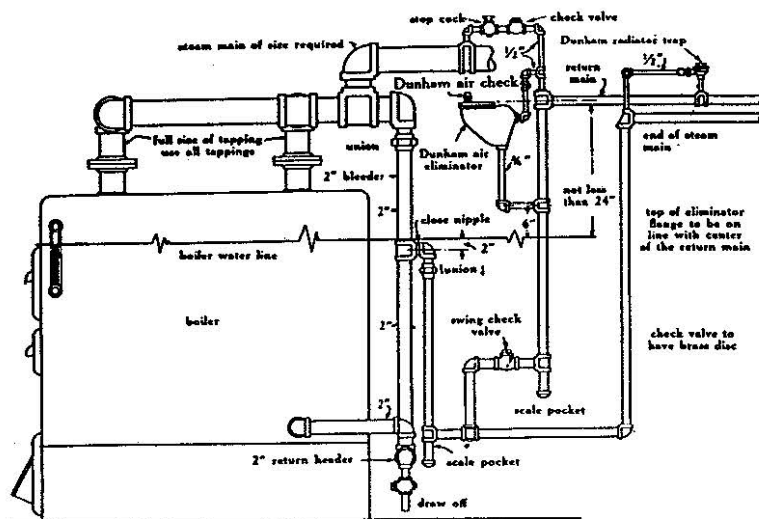

Vapor system piping to a boiler with two or more supply tapplings.

RETURN TRAP SYSTEM

This system is similar to the vapor system except that the return trap provides a positive return of condensate to the boiler. A return trap system can be used in any size building providing the EDR capacity of the system is not greater than the return trap capacity.

Advantages are: (1) Ability to operate at higher steam pressure than the vapor system. (2) Smaller pipe sizes are possible (because of higher steam pressures). (3) The system does not require as great a skill when the boiler is hand fired. (4) The system responds more readily to thermostatic control. (5) Distribution may be balanced by the use of regulating plates or adjustable orifice valves. (6) Positive quick return of water to the boiler.

Disadvantages are: (1) The physical limitations in trap capacity. (2) The necessity for sufficient height for piping. (3) Circulation of steam depends on boiler pressure. (4) Steam can be evenly distributed only over moderately sized buildings.

Pipe sizes are listed on page 67.

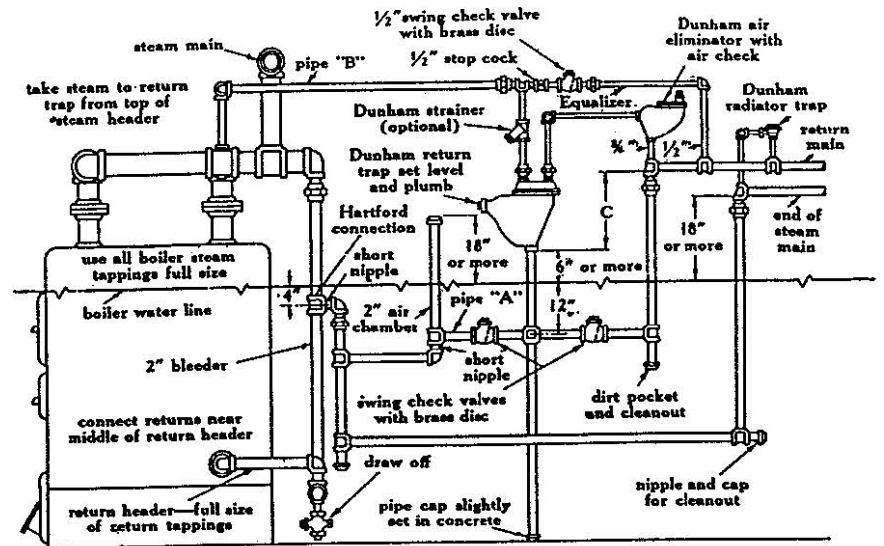

Return trap system piping connections. Note that 6" is the minimum distance between the boiler water line and the bottom of the return trap. If this dimension can be greater than 6', the capacity of the trap is increased.

CONDENSATE RETURN SYSTEM

When the system is limited as to capacity or height of the boiler water line or of a size so that a return trap cannot be used, a condensation pump may be employed to return the condensate to the boiler. (See Pump Application Manual for complete data on condensation pumps).

The condensation pump must be located so that the system return line is pitched sufficiently for condensate to flow into the receiver by gravity.

Advantages in addition to those listed for the Return Trap Systems are: (1) Returns may be located below the water line. (2) Higher steam pressures are possible (limiting pressure is the safety valve setting which is 15 psi on low temperature boilers.)

Disadvantages are: (1) A vacuum cannot be produced in the return line to speed steam circulation. (2) Larger pipes and drip traps are necessary than for the vacuum return line and variable vacuum systems.

Pipe sizes are the same as those listed for the return trap system. (See page 66 and 67)

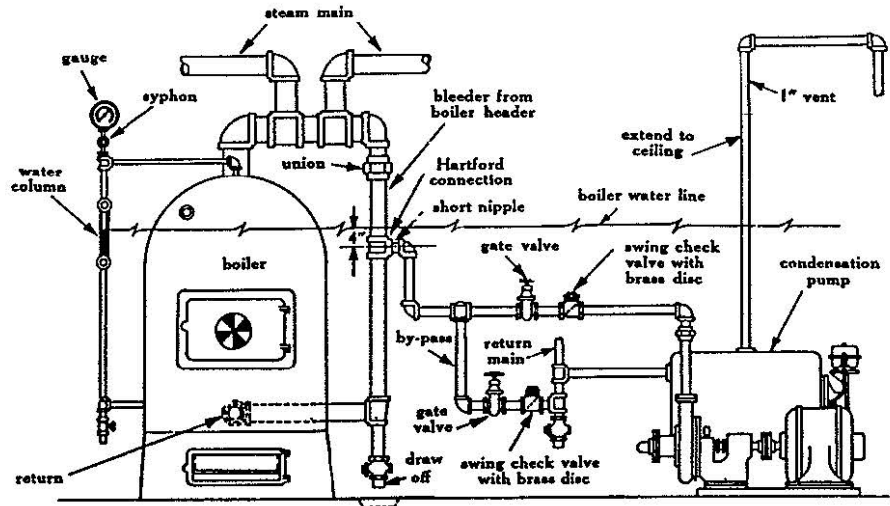

Condensate return system piping connections.

NOTE: When an outwardly opening check valve is used in the vent, a moderate vacuum can be created when the fire declines, so the system may continue to supply heat.

VACUUM RETURN LINE SYSTEM

A vacuum return line system is similar to a condensate return system except that a vacuum pump is used to maintain a low vacuum in the return pipe and return condensate to the boiler. A positive pressure is maintained in the supply piping and radiation. This system can be used in any building regardless of size or type.

Advantages are: (1) Rapid circulation of steam due to mechanical removal of air. (2) Positive return of condensate to the boiler. (3) Smaller pipe sizes due to the greater difference in pressure between supply and return lines. (4) The system may be easily converted to Vari-Vac Control with automatic circulation of steam at sub-atmospheric pressures.

Disadvantages are: (1) The cost of the vacuum pump may be too much of a burden for a small installation.

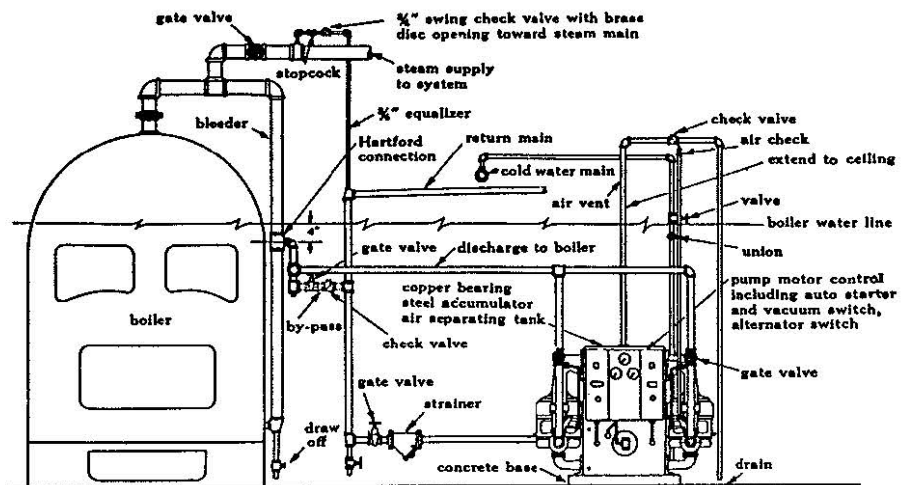

VACUUM AIR LINE SYSTEM

A variant of the One-Pipe steam heating system was the "one-pipe air line" steam heating system. In this system the radiator air vents were superseded by air valves whose outlets were connected to an air return pipe. Later, still another variant known as the "one-pipe vacuum air line" heating system appeared. This latter system included a vacuum pump for exhausting the air from the system, and the air line valves were the thermostatic type.

When an existing one-pipe gravity steam heating system is equipped with an "air-line vacuum pump", a vacuum air-line steam heating system is obtained and is the usual extent of the present day practice in the application of such systems. Air line valves (thermostatic type) are installed on each radiator in place of the usual air vent. Each air line valve is connected into the air return piping system which is connected to the suction of the air line pump.

Advantages are: In addition to those of the one-pipe gravity system are: (1) Speedier circulation. (2) Radiators heat at lower pressure. (3) Air Vents with their hissing noise and odors are not needed.

Disadvantages are: (1) Piping and radiator valves must be large. (2) Flow of water in the same pipe often makes operation noisy.

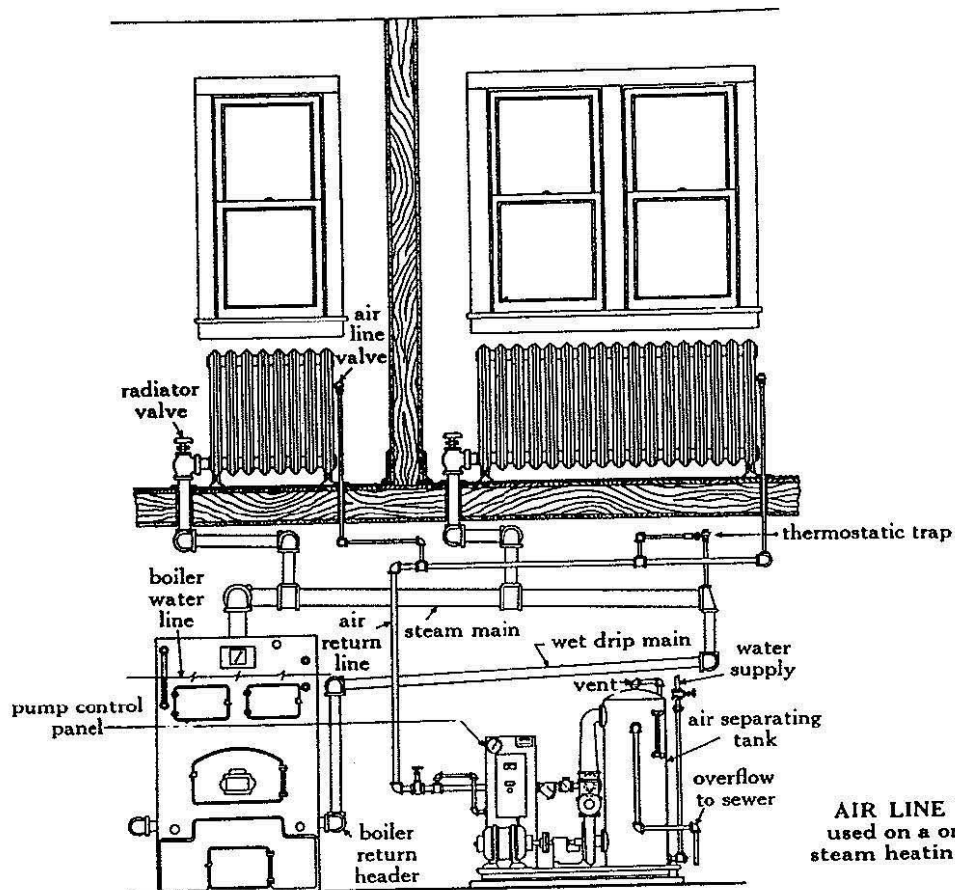

VARIABLE VACUUM SYSTEM

The variable vacuum system differs from the return line vacuum system in that it varies the pressure at which steam is used in the radiation to vary its temperature and consequently the heat emission from the radiator. The pressures range from a positive value above atmosphere down to a high vacuum (low absolute pressure). The range of radiator temperatures used approaches those commonly obtained with hot water heating systems. The steam supply is continuous and its rate is controlled, either by regulating its generation or its admission to the supply piping. The vacuum pump controller maintains the return piping at a lower pressure than that in the supply piping by a small difference. The supply side of the system operates under a vacuum, as required, and the returns at a relatively higher vacuum. When operating at positive pressures, a low vacuum is maintained in the return piping to accelerate the steam circulation.

The piping is the same as to sizing and design as the return line vacuum system. Lift connections if used are restricted to a single lift between the vacuum pump and accumulator tank by gravity. All condensate should flow to the accumulator tank by gravity.

Advantages In Addition To Those Listed For The Return Line Vacuum System. And The Condensate Return System are: (1) **Quick response** to temperature changes. (2) **Balanced heat distribution.** (3) **Room temperatures are controlled** by thermostatic control of the (a) fire or burner— or (b) steam supply. (4) **Steam is supplied continually** — the operation is not intermittent during weather conditions when such would be uncomfortable. (5) **Various types of radiation may be used** with good results. (6) **Operates at higher temperatures** to meet extreme weather conditions. (7) **More uniform floor-to-ceiling temperatures.**

Disadvantages are: (1) **The vacuum pump cost may require too large an investment for the small systems.**

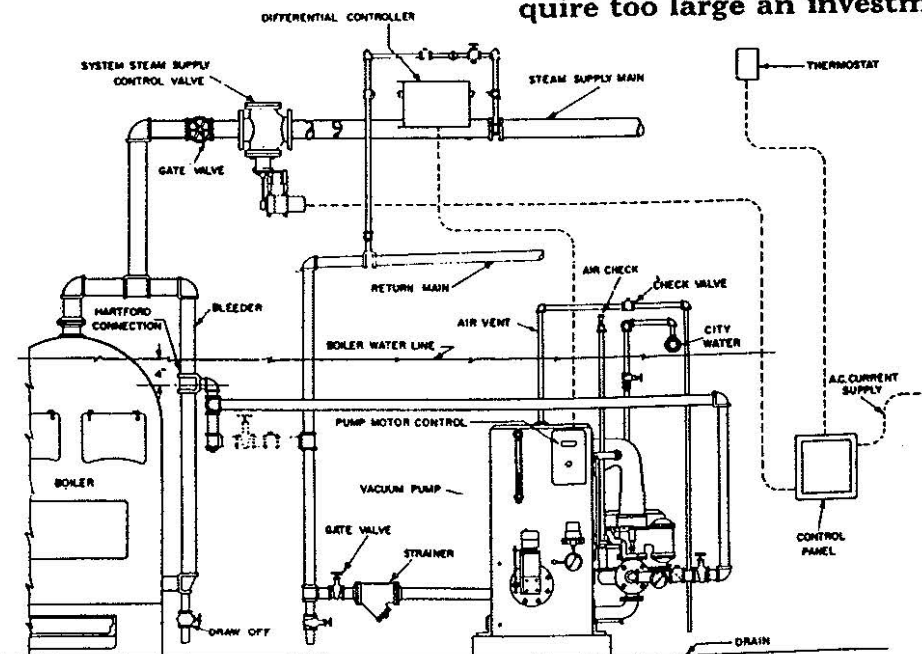

TWO-PIPE "MEDIUM" AND HIGH PRESSURE SYSTEM

High pressure steam (ranging from over 25 to 125 psi) is used primarily for steam process equipment—kettles, water heaters, garment presses, dryers, dairy equipment, etc. The two-pipe high pressure steam space heating system results from the desirability or convenience of using this high pressure steam for space heating.

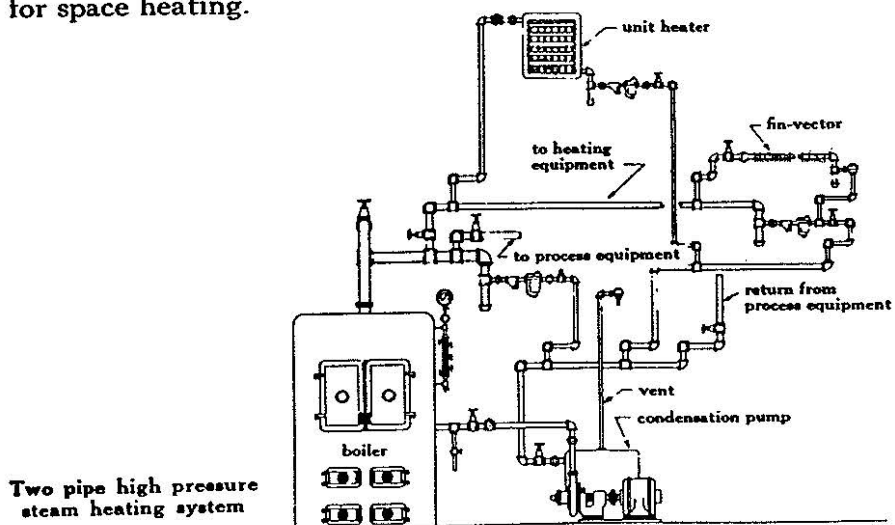

Two pipe high pressure steam heating system

Space heating with high pressure steam is usually provided by unit heaters, Fin-Vector radiation or fan units with blast coils. Inverted bucket traps or high pressure thermostatic traps are commonly used for venting air and handling condensate from this heating equipment (see illustration above).

Advantages are: (1) **Smaller pipe sizes.** (2) **Smaller heat exchange units.** (3) **Simplified piping system** (steam at boiler pressure may be used in common for both process work and heating. Also, there may be a common system of return piping). (4) **Condensate may be elevated** (where a sufficient minimum differential continually exists, condensate may be lifted into return mains). (5) **High Pressure condensation or boiler feed pumps discharge all returned condensate directly to boiler(s).**

Disadvantages are: (1) **Higher final air temperatures.** Hence, care must be exercised in selecting and locating unit heaters, etc., Fin-Vector radiation must be distant from occupants so as not to cause discomfort. (2) **Temperature control is more difficult.** Except where the piping for space heating is on a separate zone, the pressure and corresponding temperatures of the steam as required for process work must be used for space heating; consequently, steam pressure cannot be varied in keeping with heat loss requirements. (3) **Risk of injury to persons** by contact with hot piping or other apparatus. (4) **Higher maintenance costs.** Equipment operated on high pressure, due to the service to which it is subjected, requires more attention and consequently is more expensive to maintain.

Pipe sizes are listed on page 68.

5 Reasons Why MEPCO Seats Outlive Their 25 Year Guarantee

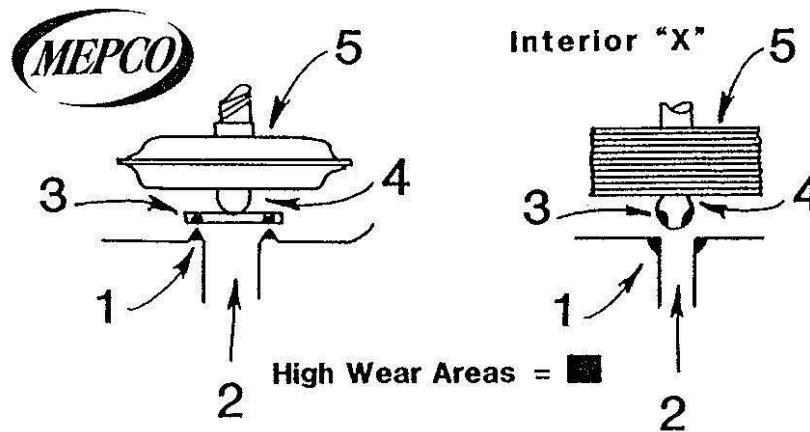

TRAP MECHANISM COMPARISON

1. UNIQUE SEAT SHAPE

The MEPCO seat features a raised rounded edge which permits intimate contact with the valve piece and leaves little area for the accumulation of encrustations. As the seat experiences wear, its unique shape allows it to abate without diminishing its performance, as illustrated above. Interior "X" enlarges its seat diameter as it wears, as illustrated above, affecting its seating ability after a short usage period.

2. LARGE SEAT DIAMETER

The MEPCO seat features an exceptionally large orifice which prevents clogging and encourages self-cleaning. Wiredraw, which occurs when any fluid flows from a region of higher pressure into a region of lower pressure through a constricted passage is reduced by the comparative low velocity resulting from the large MEPCO seat diameter. Interior "X" features a highly constricted orifice which encourages the wiredraw phenomenon.

3. FLAT FLOATING VALVE PIECE

The MEPCO flat floating valve piece features a large surface area designed to experience wear without diminishing trap performance, as illustrated above. Interior "X" with its spherical valve design or those with conical design have been shown to cut easily and exhibit wear patterns such as those illustrated above which affects its seating ability after a short usage period.

4. BALL SWIVEL JOINT

The MEPCO disc features a ball swivel joint which connects the flat valve piece to the thermostatic member. This swivel joint prevents localized stresses on the disc and also prolongs the life of the valve and seat by preventing wear in any one spot. Fixed valve pieces like that illustrated above by Interior "X" do not provide uniformity of operational concentricity. This inconsistent seating trait results in operational steam loss as well as uneven and excessive wear to both the valve piece and seat.

5. UNIQUE DISC DESIGN

The MEPCO thermostatic disc has been designed to include many trap life extending features. In addition to its proven longevity (10,000,000 plus lab tested cycles), the disc features a short stroke design which allows for the briefest valve movement possible between full open and closed positions minimizing steam loss during the closing stroke. Smooth construction presents a minimum opportunity for the accumulation of dirt and encrustations which would interfere with its positive action. The thermostatic member illustrated above in Interior "X" provides excellent crevices for movement restricting mineral accumulations. The MEPCO thermostatic disc was designed with built-in "overtravel" which, while insuring positive, consistent performance, also compensates for normal seat wear without diminishing trap performance.